

 **VULY** | 360 Swing Set



ASSEMBLY MANUAL

See [VulyPlay.com/support](https://www.vulyplay.com/support) for any updates to these instructions.

WARNING!

Minimum user age – 6 years. Only for domestic and outdoor use.

Maximum combined user weight – 80 kg. Maximum number of users – 2 people.

Adult assembly required (2 adults). Adult supervision required at all times.

Ensure that 360 is secured with anchors or bolts before use.



Contents

Read and follow all instructions in this manual before using your swing set, and do not use the swing set in any way that is not described in this manual.

Responsibility rests with the owner and supervisors of the swing set to make sure that all users are aware of the practices specified in this manual.

1.0. Care and Maintenance	4
2.0. Usage and Behaviour	4
3.0. Installation	4
3.1. Pre-assembly	4
3.2. Parts checklist	5
3.3. Assembly instructions – Vuly 360	7
4.0. Warranty	16
4.1. Warranty periods	16
4.2. Inclusions	16
4.3. Exclusions	17
4.4. Warranty Claims	17
4.5. Australian Consumer Law	17
5.0. Missing parts	17

1.0. Care and maintenance

Improper maintenance or lack of care can lead to your swing set deteriorating earlier than expected and causing injury.

Please follow these instructions to ensure that your swing set lasts for as long as possible.

- Inspect all parts at least once a month – particularly textiles and around hooks and connections.
 - Check that all push-buttons are firmly secure.
 - Ensure that all moving metal components remain well oiled with an appropriate lubricant.
 - Replace any parts showing evidence of deterioration, rusting or defectiveness immediately and only through Vuly.
- **Remove textile components (i.e. Yoga Swing) whenever not in use. Store in a cool, dry and dark place.**
- Cover during severe weather, such as extreme cold and heat.

2.0. Safety

Improper use of, or behaviour on, your swing set can lead to injury.

Warning:

- Users aged 6+ only, with a maximum combined weight of 80kg.
- Outdoor, private and domestic use only.
- Adult supervision required at all times.

Please follow these behaviour instructions to ensure safe play:

- Keep surrounding area clear at all times.
- Do not jump onto or from the swing set.
- Do not bring sharp objects near the swing set.
- Mind head while using the Yoga Swing.
- Use Vuly-made accessories and parts only.

3.0. Installation

Improper assembly can lead to instability and safety hazards. Follow all these instructions exactly as given:

3.1. Pre-assembly

- Choose a well-lit area, with flat surface, that has clearance of 2 m on all sides from all other structures and obstacles – such as walls, fences, trees, washing lines and electric wires.
- Ensure that the chosen location allows the swing set to be firmly embedded – either with the included Anchor Kit (on soft surfaces, like grass) or a bolt kit (on hard surfaces, like concrete).
- Check that you have all parts required for assembly.
- Make sure that the product is assembled by an adult.

3.2. Parts checklist

Frame

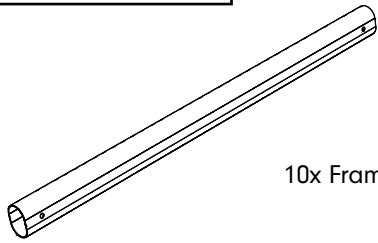

10x Frame Tubes

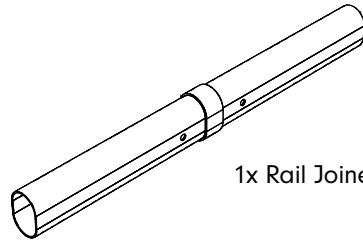

1x Rail Joiner

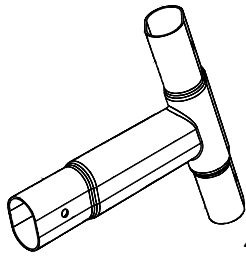

4x Frame Joiners

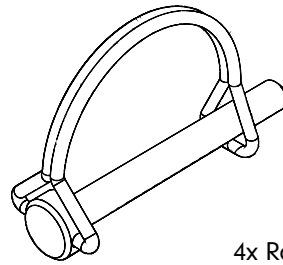

4x Rail Locking Pins

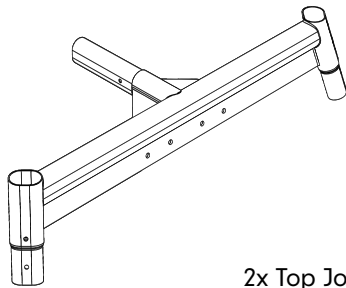

2x Top Joiners

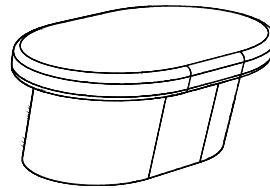

4x Top Caps

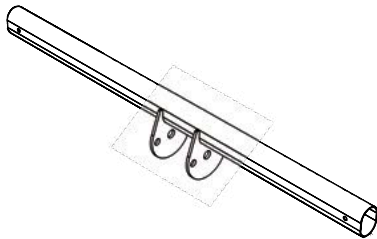

1x Spin Rail

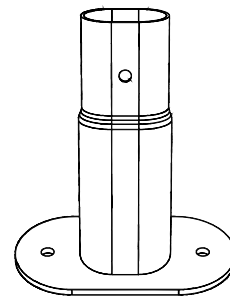

4x Feet

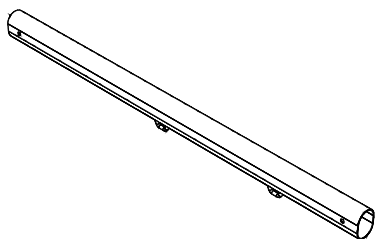

1x Swing Rail

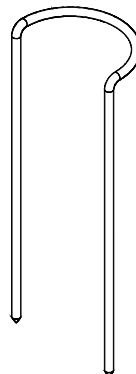

4x Anchors

Spin Swing

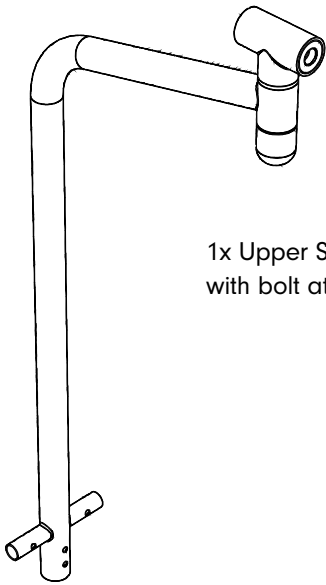

1x Upper Spin Pole, with bolt attached.

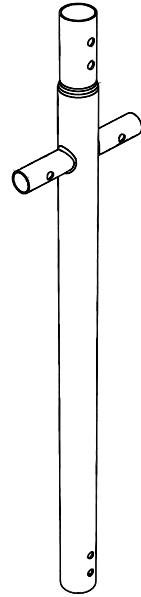

1x Lower Spin Pole

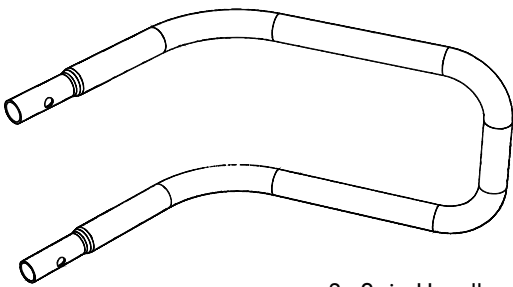

2x Spin Handles

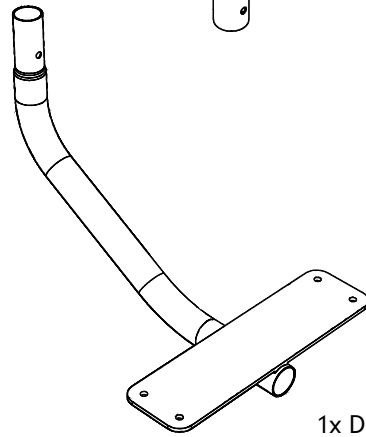

1x Deck Plate

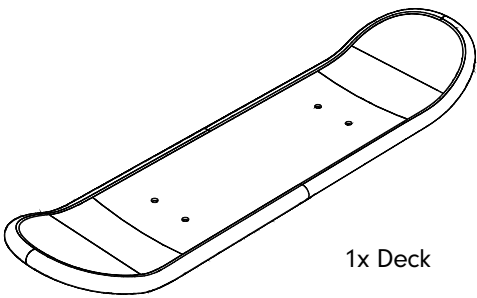

1x Deck

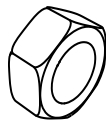

4x Deck Bolts

Yoga Swing

1x Yoga Swing, with clamps attached.

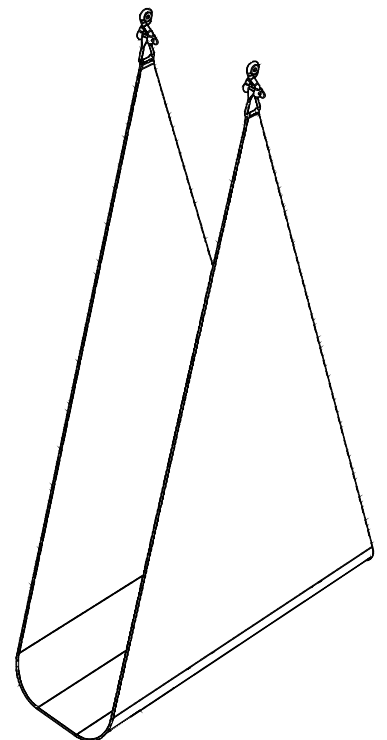

3.3. Assembly instructions – Vuly 360

3.3.1. Frame

STEP | 1

Remove all parts from the packaging, and lay out the components on the ground.

ENSURE THAT AS YOU FOLLOW THESE INSTRUCTIONS, ALL PUSH BUTTONS SECURELY LOCK.

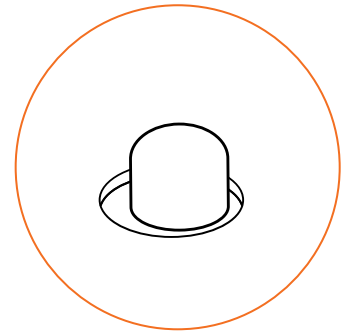

STEP | 2

Insert the Spin Rail into the centre of a Top Joiner.
Lock the two together with a Rail Locking Pin.

Insert the Swing Rail into the centre of a Top Joiner.
Lock the two together with a Rail Locking Pin.

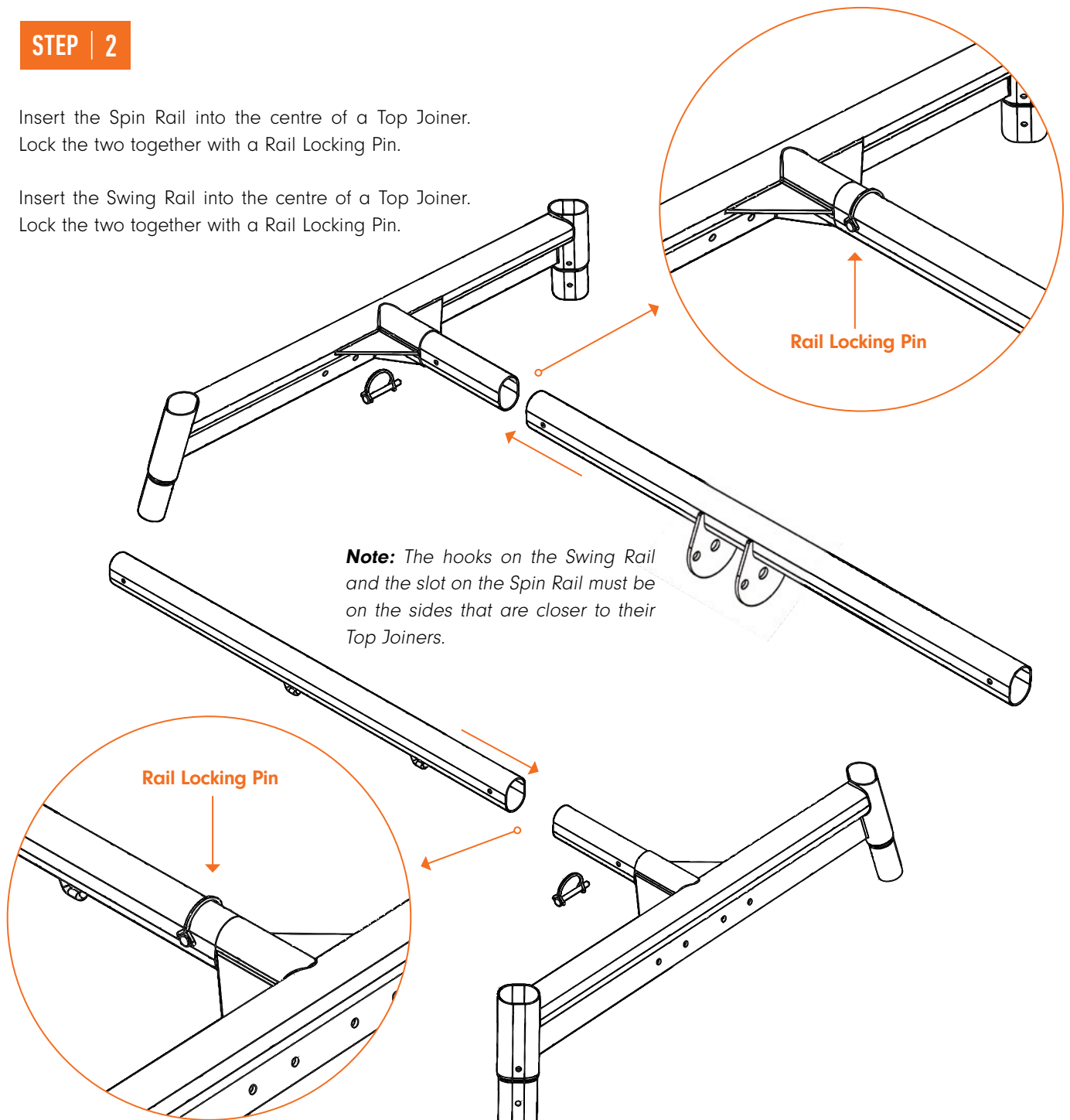

STEP | 3

Connect these two completed parts to either side of the Rail Joiner, and lock them in with two Rail Locking Pins.

Insert the Top Caps onto the top corners of each Top Joiner.

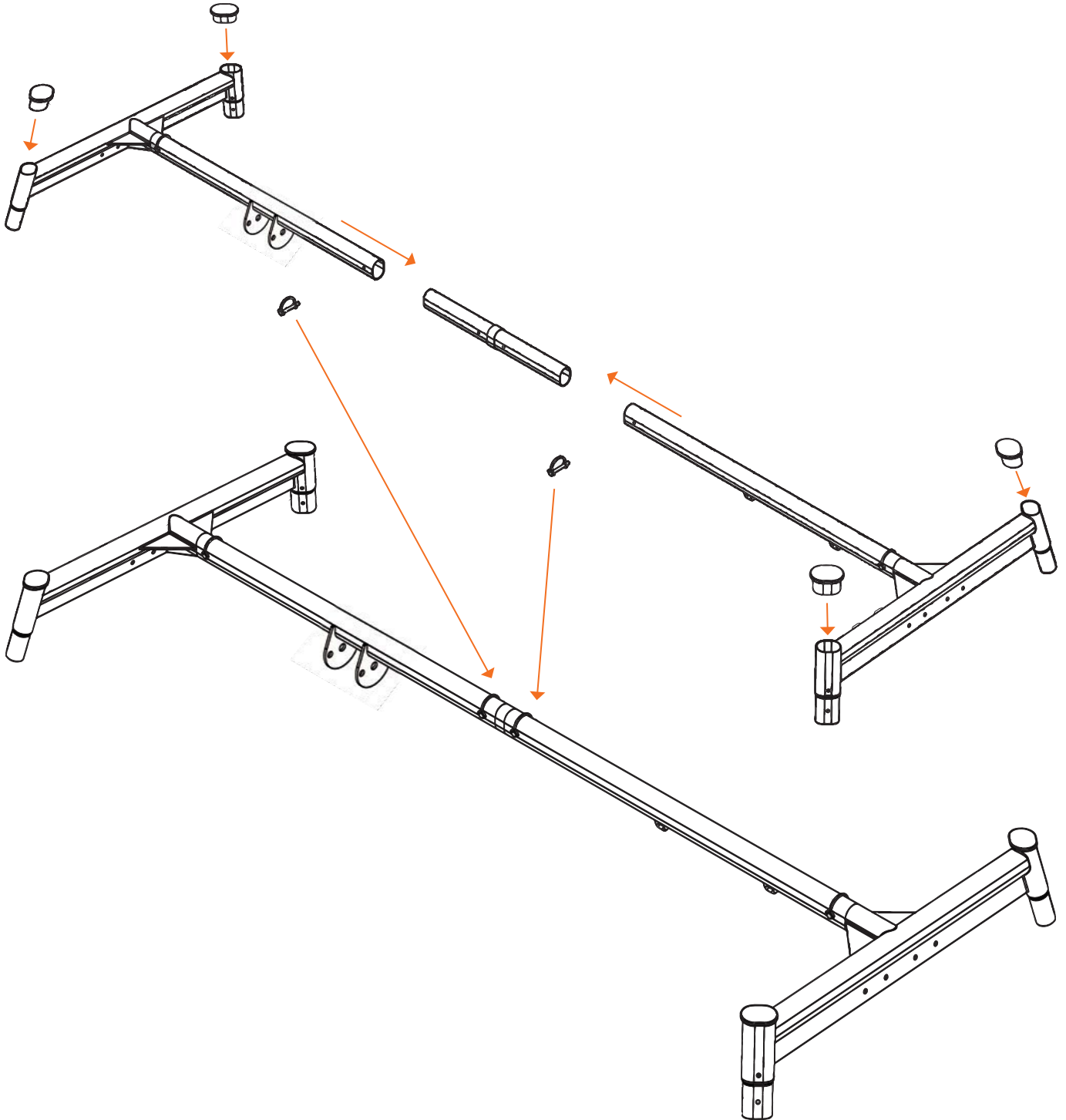

STEP | 4

Insert four Frame Tubes into the bottoms of each Top Joiner, as though you are 'standing up' the frame.

ENSURE THAT ALL PUSH BUTTONS SECURELY LOCK DURING ASSEMBLY.

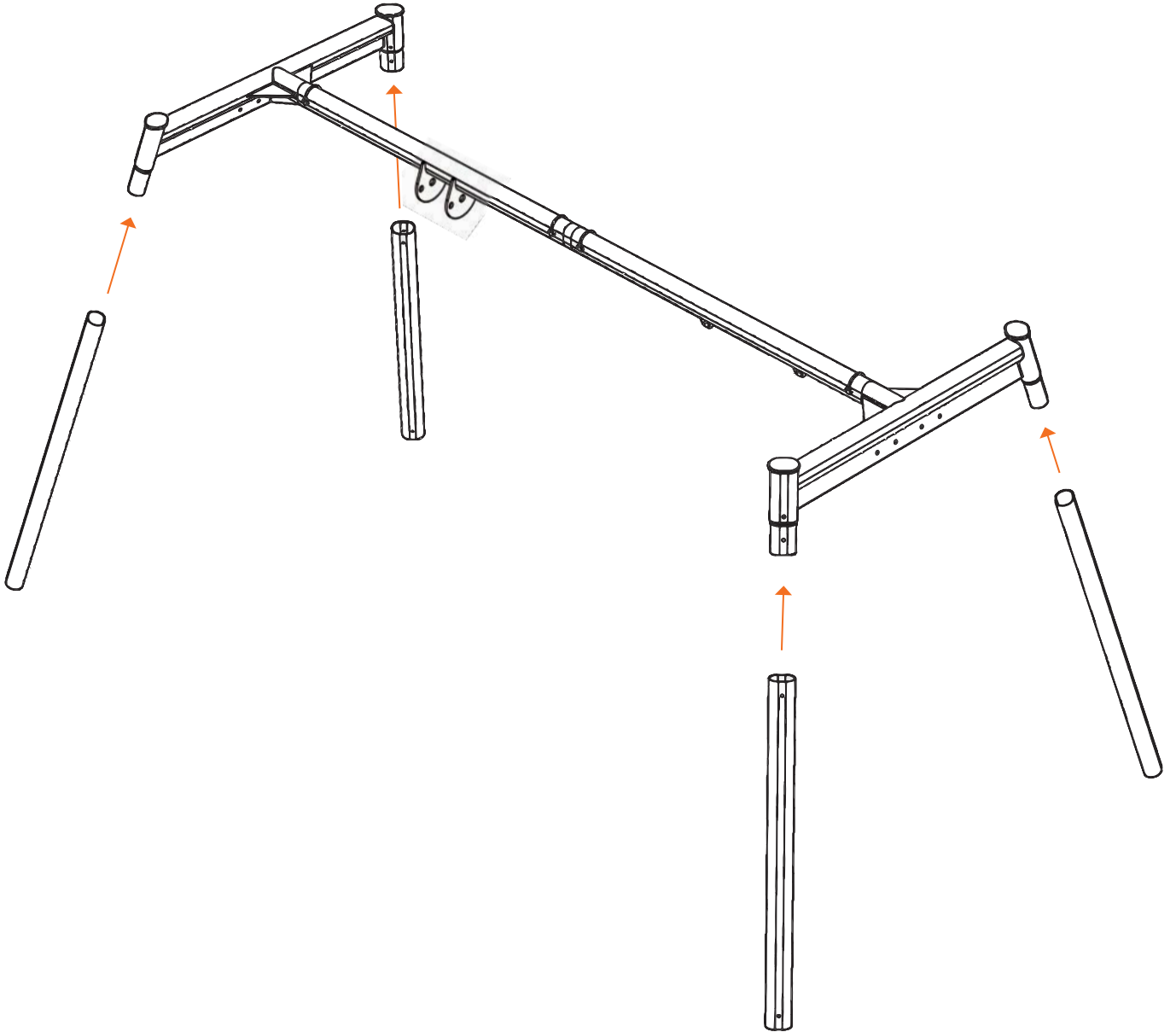

Skip this section if you **do not** wish to attach your Shade Cover.

STEP | A

Lay your Shade Cover out on top of your partially-assembled swing set.

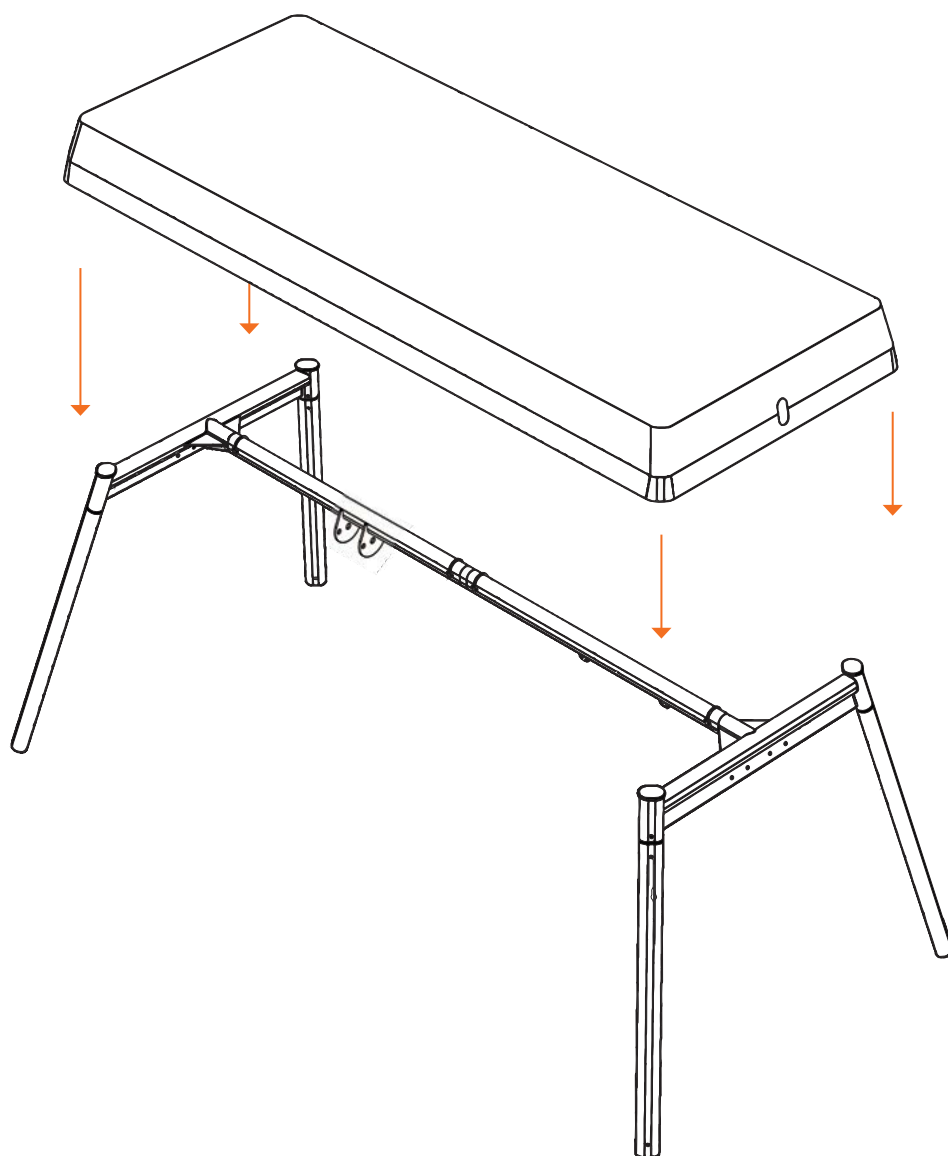

STEP | B

Pull two corners down over the Top Joiners, and insert the toggles. Go to the other side of the swing set and repeat for the other two corners.

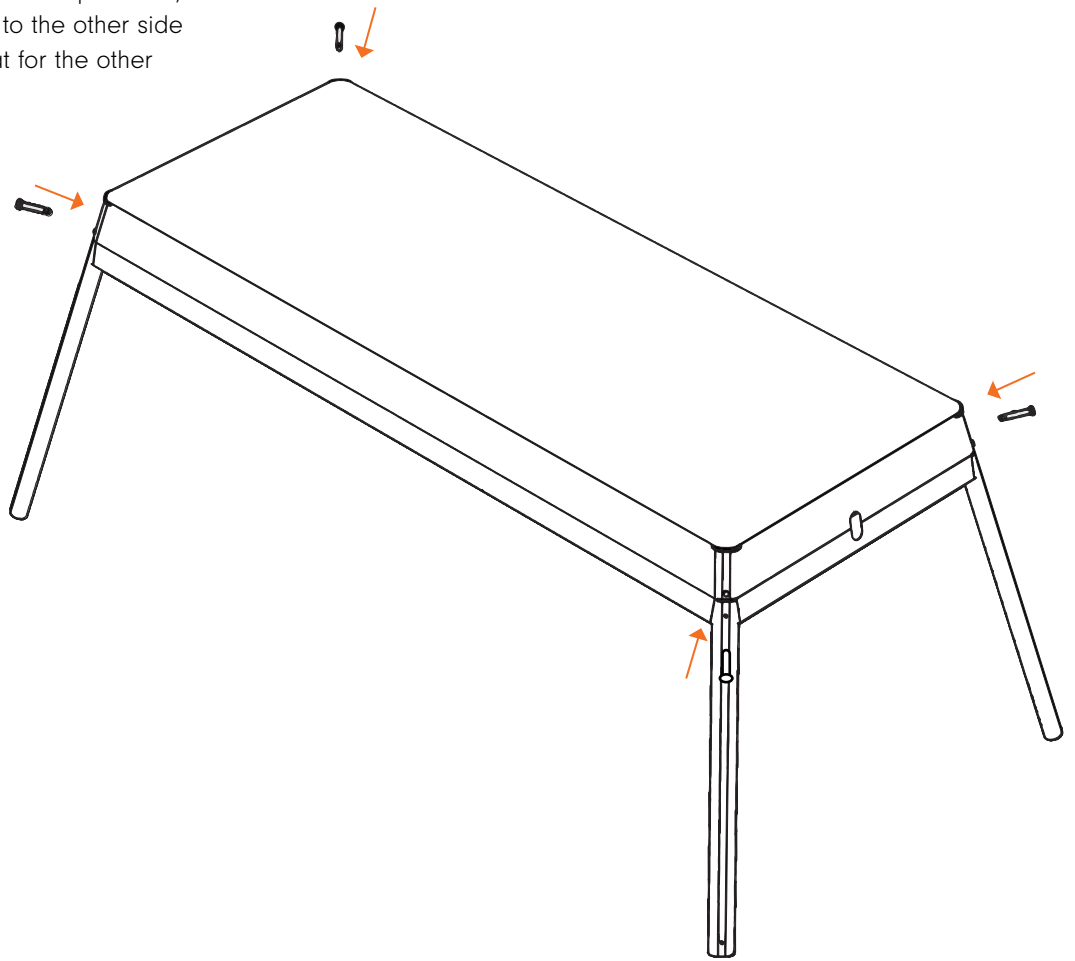

STEP | 6

Connect two Frame Joiners onto either end of one Frame Tube.

Repeat for a second Frame Tube and Frame Joiners.

ENSURE THAT ALL PUSH BUTTONS SECURELY LOCK DURING ASSEMBLY.

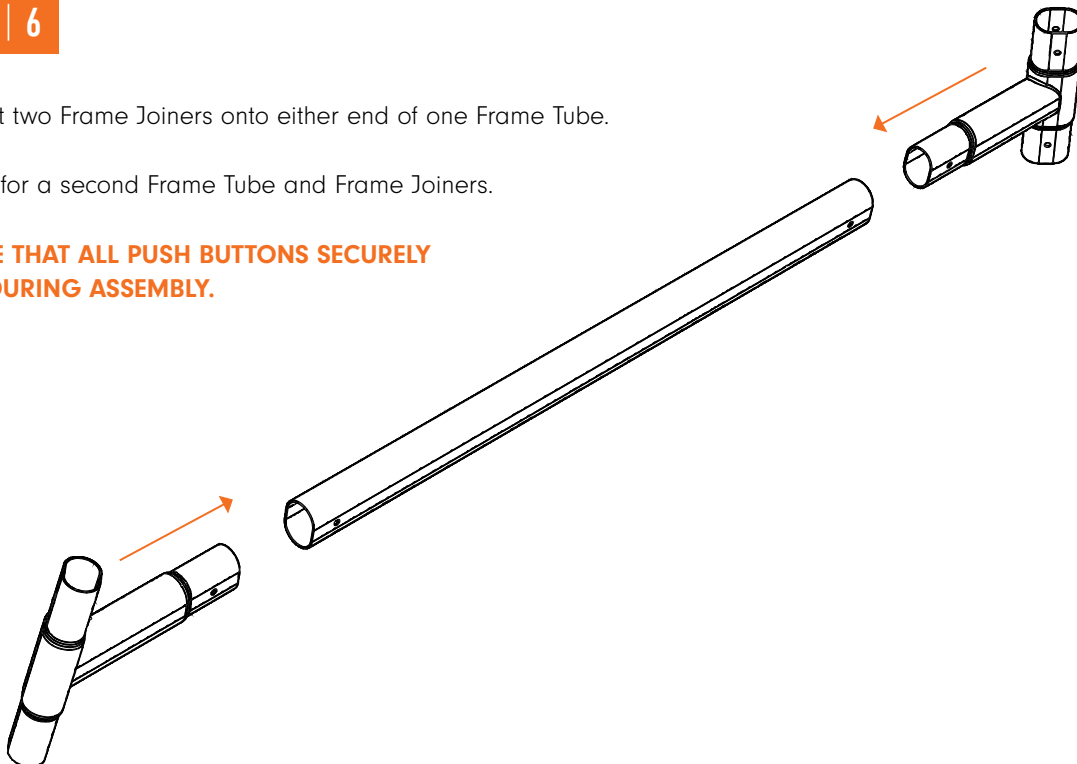

STEP | 7

Take your two Frame Tube and Frame Joiner parts from Step 6 and insert them into the Frame Tubes on both sides of the swing set.

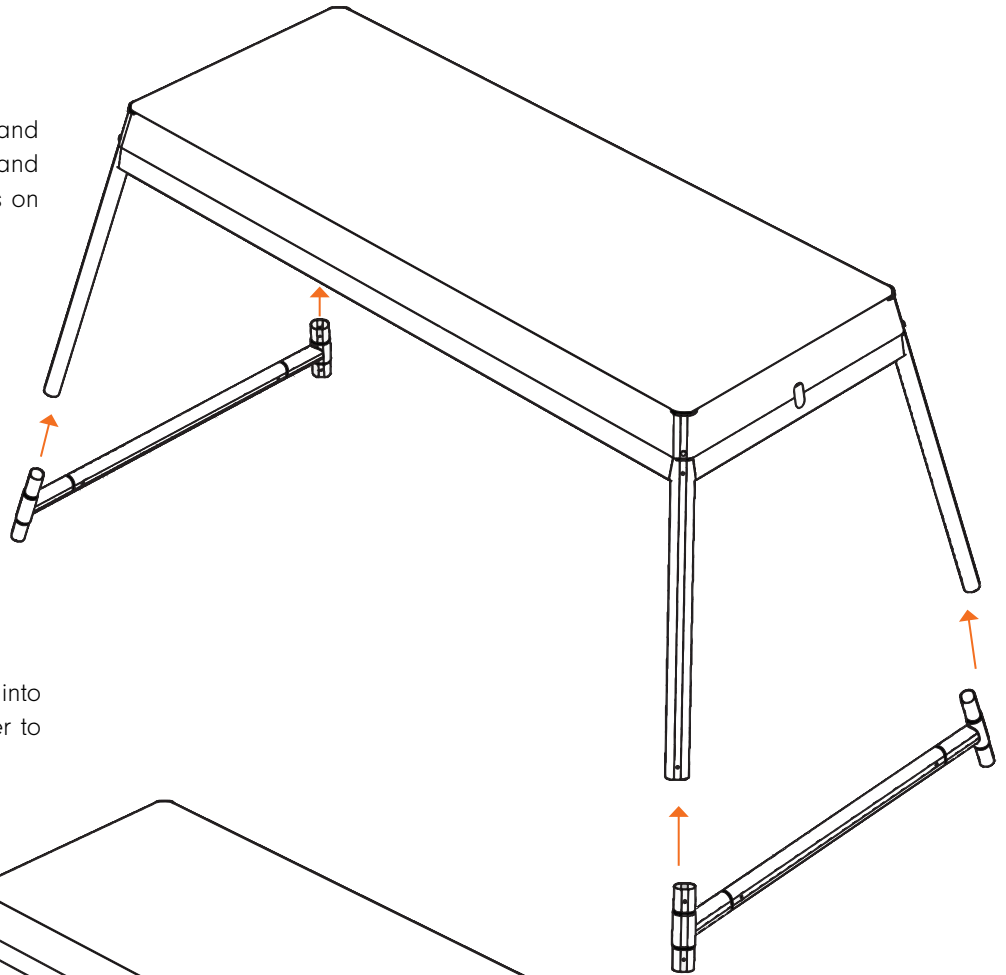

STEP | 8

Insert your final two Frame Tubes into the bottoms of each Frame Joiner to form the legs.

Insert the Feet underneath each Frame Tube leg.

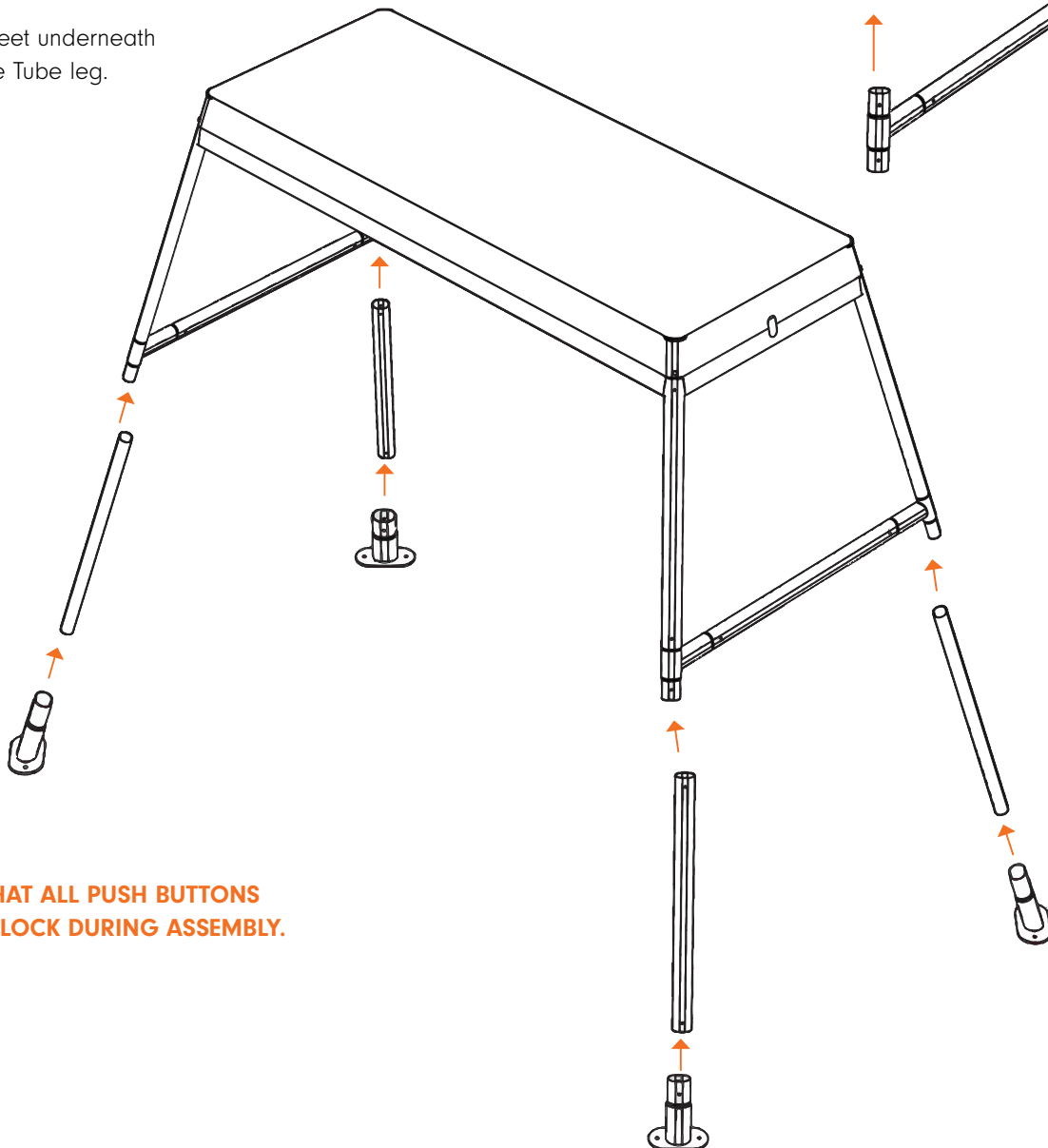

**ENSURE THAT ALL PUSH BUTTONS
SECURELY LOCK DURING ASSEMBLY.**

STEP | 9

Drive the Anchors through the holes in each Foot to secure the swing set to the ground.

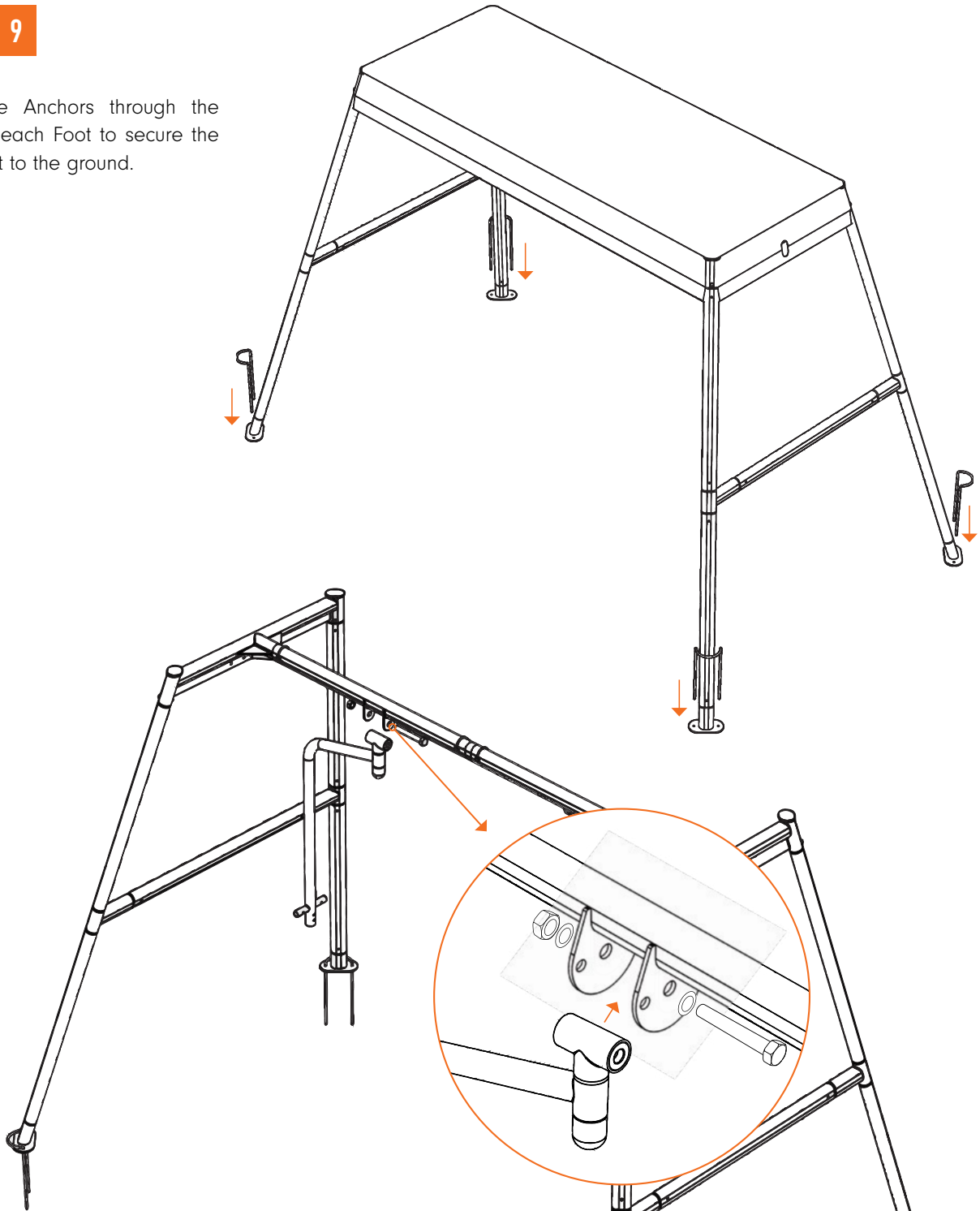

3.3.2. Spin Swing

STEP | 10

Remove the bolt, nut and washers included with the Upper Spin Pole, and position the barrel end of the Upper Spin Pole in the open slot on the Spin Rail.

Insert and tighten the nut and bolt – ensuring that the washers are on both sides – and then sinners the pin to secure it.

Note: To adjust how easy or difficult it is to ‘spin’ on the Spin Swing, remove the rubber cap at the base of the barrel.

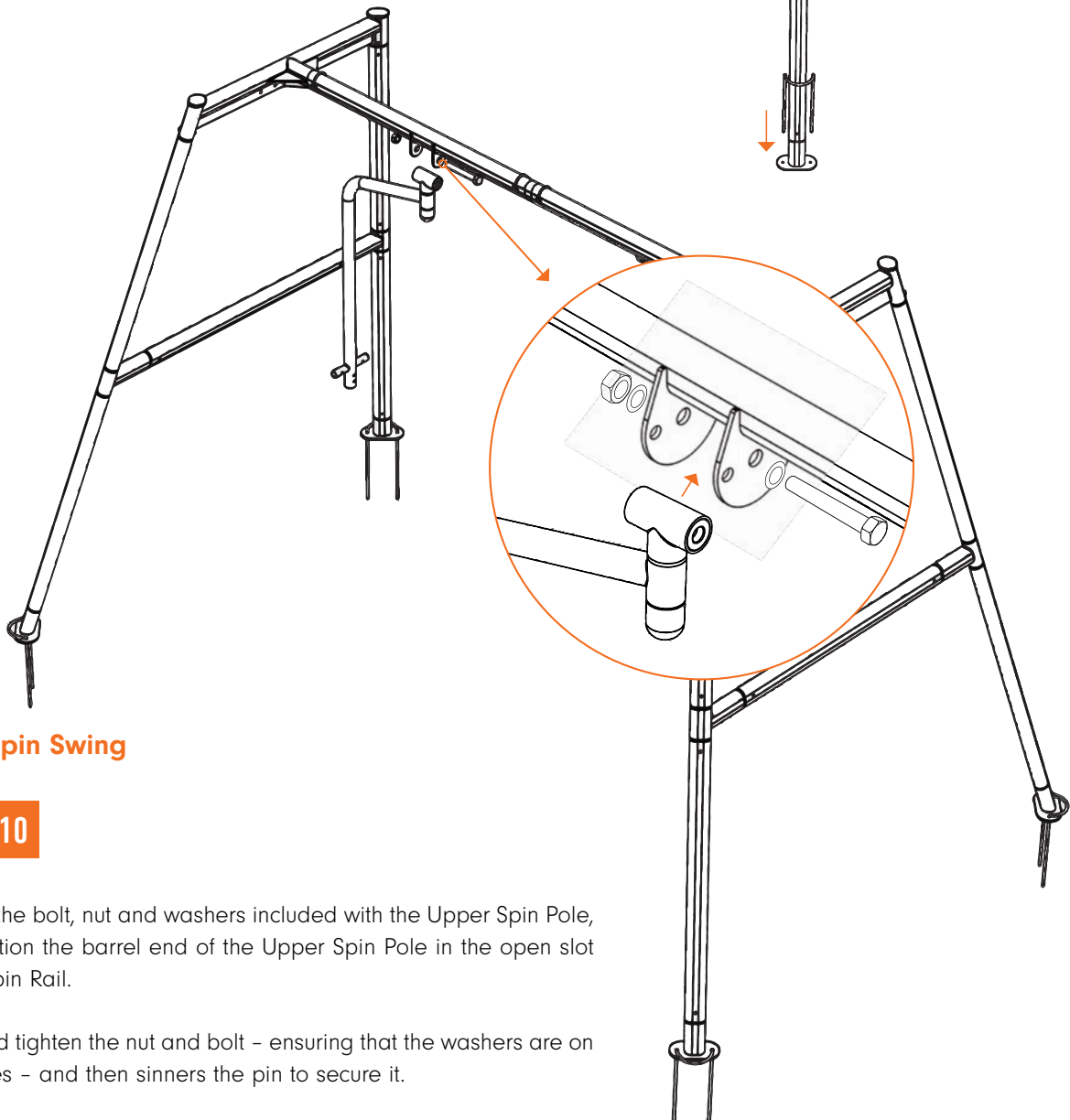

STEP | 11

Insert the Lower Spin Pole into the bottom of the Upper Spin Pole, and insert the Deck Plate into the Lower Spin Pole.

Insert the Spin Handles at the connection between the Upper and Lower Spin Poles.

ENSURE THAT ALL PUSH BUTTONS SECURELY LOCK DURING ASSEMBLY.

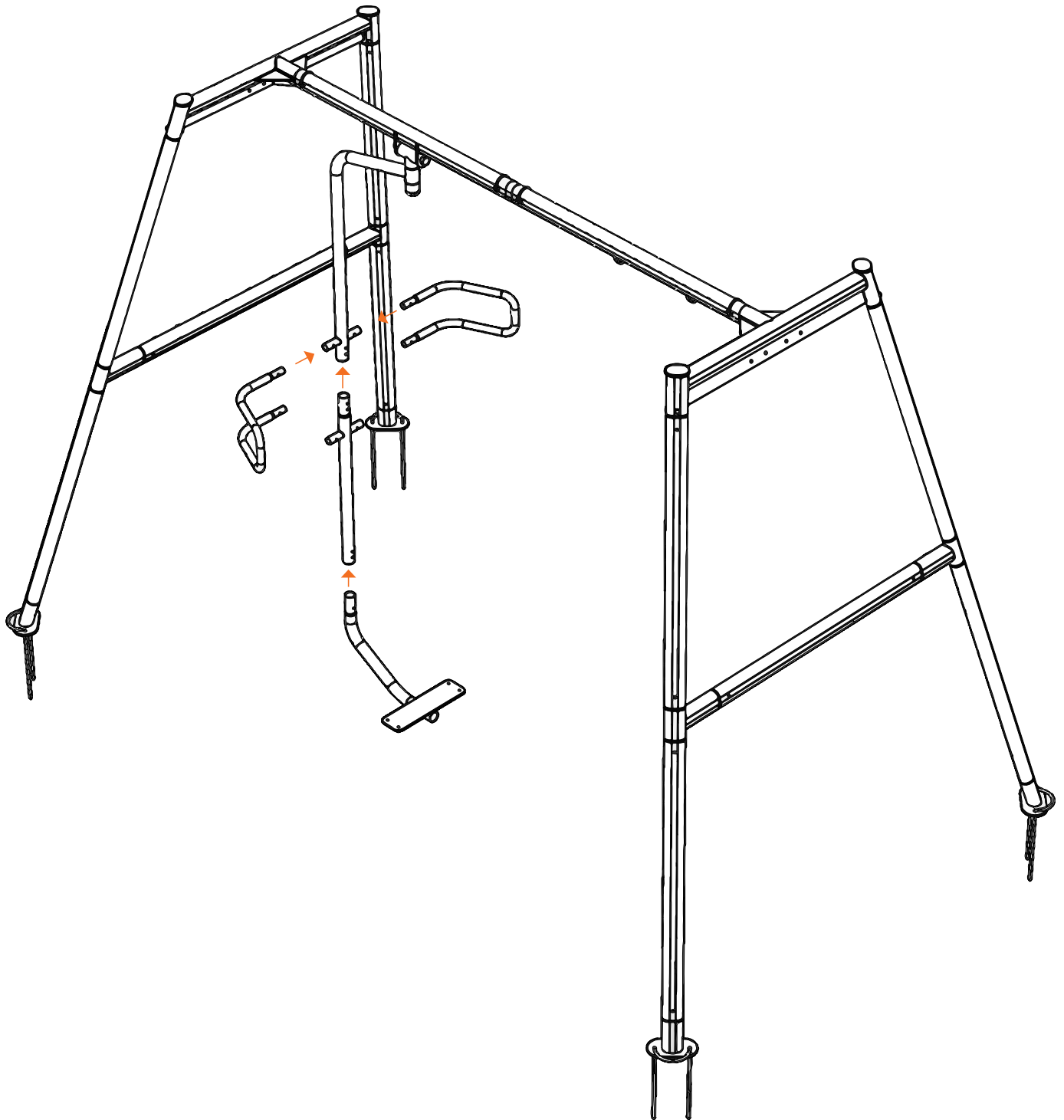

STEP | 12

Position the Deck onto the Deck Plate, ensuring that the holes on both line up.

Insert the four Deck Bolts through the top holes of the Deck, and secure them by tightening the nuts underneath.

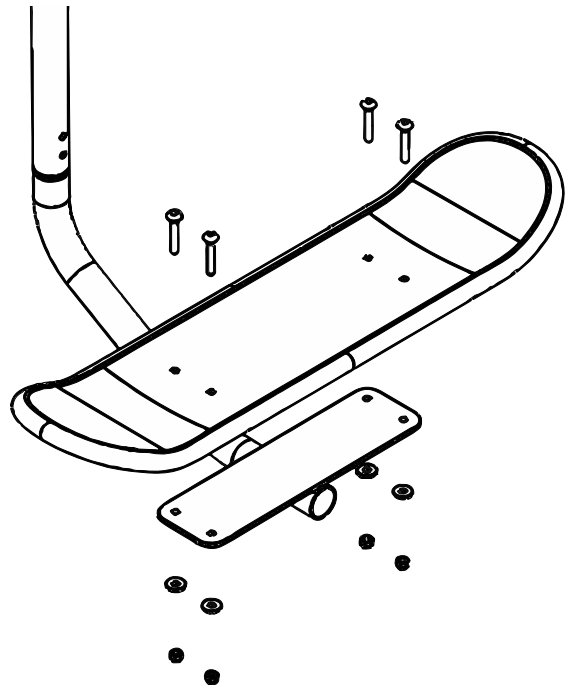

3.3.3. Yoga Swing (or Classic Swing)

STEP | 13

Attach the Yoga Swing (or Classic Swing) - with the clamps - to the hooks in the Swing Rail.

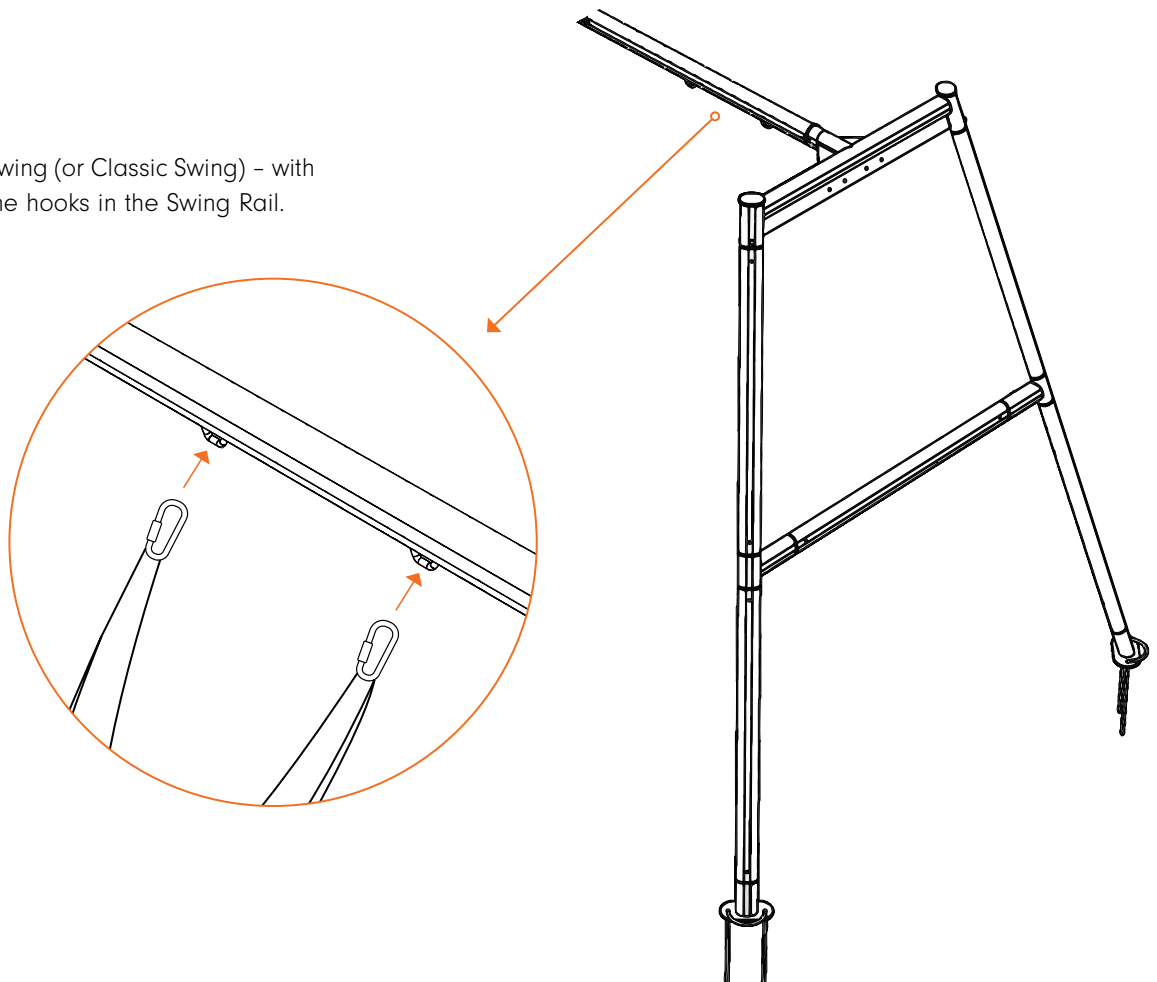

CONGRATULATIONS!

You have assembled your Vuly 360 swing set!

4.0. Warranty

All Vuly products are sold with a manufacturing warranty, which assures that the item is free of defects in workmanship and materials (“warranty”).

Vuly offers the longest and most extensive warranties in the market on all our products. We provide comprehensive after-sales service, which we believe encourages the customer to purchase a Vuly product instead of those of our competitors.

4.1. Warranty periods

Warranty periods do not reset for any reason, unless the customer purchases a new product. In this case, that particular item will be covered by its own warranty period. It does not affect – nor will it increase – warranty periods for other purchased items.

Warranty periods always commence from the date of item delivery.

This warranty is for use under normal conditions, and it applies for:

SWING SETS

- 120 months [10 years] to the metal Frame components.
- 36 months [3 years] to metal Swing components (e.g. Spin Swing).
- 12 months [1 year] to textile components (e.g. Yoga Swing).

ACCESSORIES

- 12 months [1 year] to purchased accessories not received during a promotional period.
- 3 months to any items received at no cost as part of a promotion – e.g. ‘Free Shade Cover’.

The customer may extend the standard 12-month [1 year] warranty to 36 months [3 years], if they purchase an extended warranty within 7 days of their delivery date.

4.2. Inclusions

This warranty covers manufacturing faults and defects only.

If a product is damaged or rendered unsafe as a result of a departure from its design specifications during production, this constitutes a manufacturing fault or defect.

This may occur if – for example – improper welding during manufacturing produces an unstable Frame.

4.3. Exclusions

4.3.1. Damage through wear and tear

This warranty does not extend to normal wear and tear of the product. This may include, but is not limited to:

- Rusting or scratching of steel components,
- UV deterioration of textile components.

As outdoor products that are actively used, swing sets and their accessories will experience wear and tear over time.

4.3.2. Damage through weather conditions

Damage to the product that results from weather events – such as rain or wind – are not covered under the warranty. Vuly suggests that you contact your home and contents insurer if your product is damaged by such events.

4.3.3. Damage through improper installation

This warranty does not extend to any failure of the product caused by installation not in accordance with the Vuly Manual. Customers must assemble their Vuly product by following carefully the Installation section of their Vuly Manual.

Furthermore, the warranty does not cover installation provided by a third-party assembly service. It is the customer’s responsibility to check all boxes and confirm that all components are included in the correct condition before installing.

4.3.4. Damage through insufficient care or maintenance

This warranty does not extend to accelerated decay of the product caused by poor care or maintenance. It is essential that customers regularly check, and follow the advice of, the Care and Maintenance sections of their Vuly Manual to ensure that their product lasts as long as possible.

4.3.5. Damage through inappropriate use

This warranty will be void if the product is used for any other activity besides those for which it was intended. Vuly products constitute recreational outdoor products and accessories for such products. They are not intended for professional use.

Any evidence that inappropriate actions that have led to product failure will not be covered by the warranty. Similarly, replacement parts or repairs needed to mend such damage will not be covered under the warranty.

4.3.6. Personal Injury

The warranty does not cover personal injury or losses due to any of the above: wear and tear, weather conditions, inappropriate installation, insufficient care or maintenance

or inappropriate use, nor does it cover damage due to negligence or accidents.

4.4. Warranty Claims

If a customer believes that a Vuly product is faulty or defective, they must discontinue use and submit a Warranty Claim.

A customer must not attempt to use a product if any part is faulty or defective, as it may be dangerous. Any damage that the user causes as a result of using faulty or defective products will lead to voiding of the warranty.

4.4.1. Making a Warranty Claim

To fulfil a warranty claim, a customer must submit an online Warranty Claim at www.vulyplay.com/support.

Submitting the online Warranty Claim form requires the customer to provide:

- Details of their purchase – including date,
- Batch number,
- Clear photographic evidence of the manufacturing fault or defect.

If the customer does not provide all details that the form requires, their Warranty Claim will not be assessed.

Vuly may take up to 7 days to process Warranty Claims upon a completed submission. It may take a further 7 days for replacement parts to reach the customer.

4.4.2. Successful Warranty Claims

If Vuly accepts a customer's Warranty Claim, Vuly will replace the faulty or defective parts, not offer refunds.

Successful Warranty Claims lodged within 7 days of the delivery date.

Vuly will replace the damaged parts free of charge. Vuly will also cover any costs associated with shipping the replacement part.

Successful Warranty Claims lodged after 7 days of the delivery date.

Vuly will replace the damaged parts free of charge. The customer must cover any costs associated with shipping the replacement part.

4.4.3. Refunds

In all instances of successful warranty claims, Vuly offers replacements parts only. Vuly provides refunds only at their discretion.

4.4.4 Claiming on non-Vuly products

Products sold alongside Vuly that are not Vuly-branded are subject to the warranties provided by the companies that supply them. The customer must contact these external companies to make a warranty claim; Vuly itself will not assess claims made against non-Vuly products.

4.5. Australian Consumer Law

Our Goods come with guarantees that cannot be excluded under the Australian Consumer Law. You are entitled to a replacement or refund for a major failure and for compensation for any other reasonably foreseeable loss or damage.

You are also entitled to have the Goods repaired or replaced if the Goods fail to be of acceptable quality and the failure does not amount to a major failure.

5.0. Missing parts

If a customer believes that their Vuly product does not include all necessary parts or boxes, they must contact Vuly immediately on 1300 667 514.

A customer must not attempt to use a product if any part is incomplete, as it may be dangerous. Any damage that the user causes as a result of using incomplete products will lead to voiding of the warranty.

Vuly products are delivered to Vuly HQ prepackaged; we are unable to check the boxes prior to delivery to ensure that they contain all the required parts.

While the incomplete delivery and missing parts rates are low, some parts may also fall out in transit due to small, unintentional tears in their boxes and boxes may become misplaced during delivery.



vulyplay.com